

**MALAGUTI**  
EARTHMOVING EQUIPMENT



**TORNADO**  
**WURZELSTOCKFRÄSE**

**DIREKTANTRIEB**

DAS KOLBENMOTOR-DIREKTAN-  
TRIEBSSYSTEM BIETET  
MAXIMALE SCHNEIDGESCHWINDI-  
GKEIT BEI OPTIMALER  
PRODUKTIVITÄT UND EFFIZIENZ

**ZÄHNE AUS WOLFRAM**

EXTREM STARKE  
WOLFRAMZÄHNE

**GEEIGNET FÜR STEILE HÄNGE**

EFFEKTIV AUCH AN SCHWIERIGEN  
HÄNGEN, IDEAL ZUM  
FRÄSEN AUCH SCHWER  
ZUGÄNGLICHER BAUMSTÜMPFE

**SCHNELL UND EFFEKTIV**

INDEM MAN DAS ZAHNRAD VON  
EINER SEITE ZUR ANDEREN  
SCHWENKT, RÜCKT ES ALLMÄHLICH  
IN DEN STUMPF VOR, BIS  
ES VOLLSTÄNDIG BESEITIGT IST

# TORNADO

## MALAGUTI

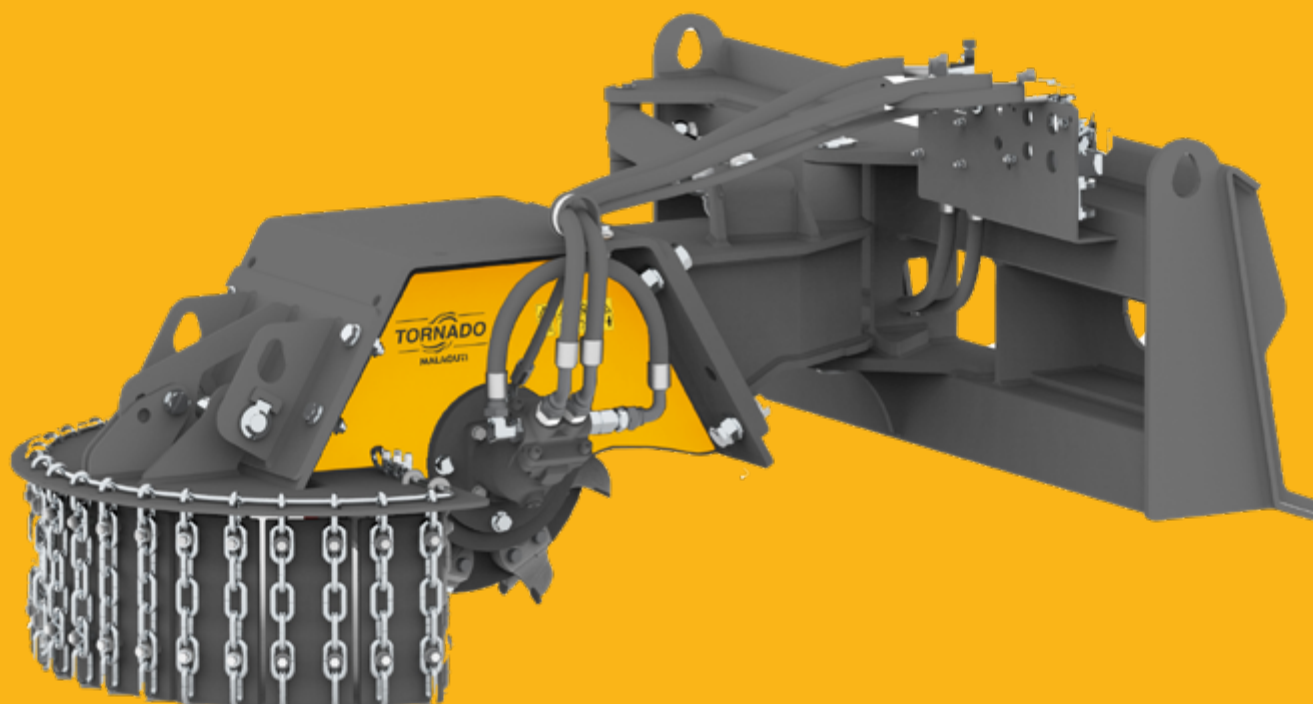

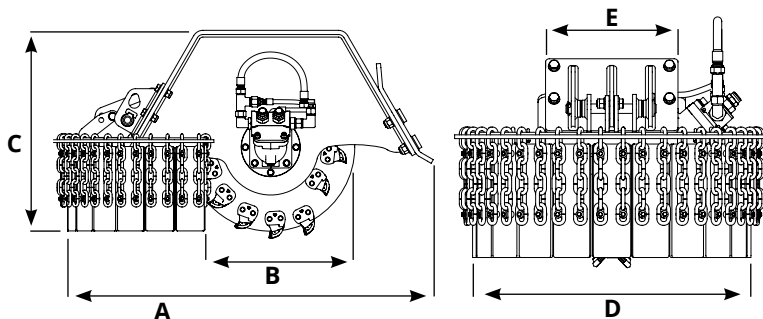

TORNADO	Tornado 350	Tornado 350	Tornado 450	Tornado 450	Tornado 450	Tornado 600	Tornado 600	Tornado 600	Tornado 600 PLUS
TONS	1.5 - 4.5	1.5 - 4.5	4.5 - 9.0	4.5 - 9.0	4.5 - 9.0	9.0 - 13.0	9.0 - 13.0	9.0 - 13.0	13.0 - 18.0
A (mm)	930	930	1150	1150	1150	1360	1360	1360	1360
B (Ømm)	350	350	450	450	450	600	600	600	600
C (mm)	494	494	572	572	572	740	740	740	740
D (mm)	710	710	720	720	720	840	840	840	840
E (mm)	350	350	350	350	350	350	350	350	350
Motor (CC)	12	18	25	28	32	45	50	63	80
Öldurchsatz (L/Min)	16	24	32	36	42	56	64	80	110
Gewicht ohne Kupplung (Kg)	140	140	226	226	226	360	360	360	375
Anzahl der Zähne	16	16	20	20	20	28	28	28	28
Druck (BAR)	200-250	200-250	200-250	200-250	200-250	200-250	200-250	200-250	200-250
Max. Gegendruck (BAR)	15	15	15	15	15	15	15	15	15

	Model	A mm	B mm	C mm	Kg.
1	ADAPTER FOR QUICK COUPLING for 350	/	/	/	/
	ADAPTER FOR QUICK COUPLING for 450	/	/	/	/
	ADAPTER FOR QUICK COUPLING for 600	/	/	/	/
2	FIXED COUPLING MACHINE for 350	/	/	/	/
	FIXED COUPLING MACHINE for 450	/	/	/	/
	FIXED COUPLING MACHINE for 600	/	/	/	/
3	BOLTED PLATE MACHINE COUPLING for 350	350	280	10	13
	BOLTED PLATE MACHINE COUPLING for 450	380	350	12	17
	BOLTED PLATE MACHINE COUPLING for 600	470	280	15	16.5

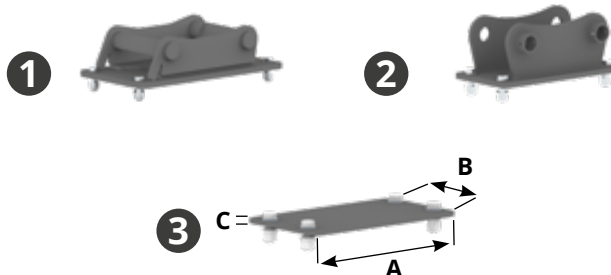

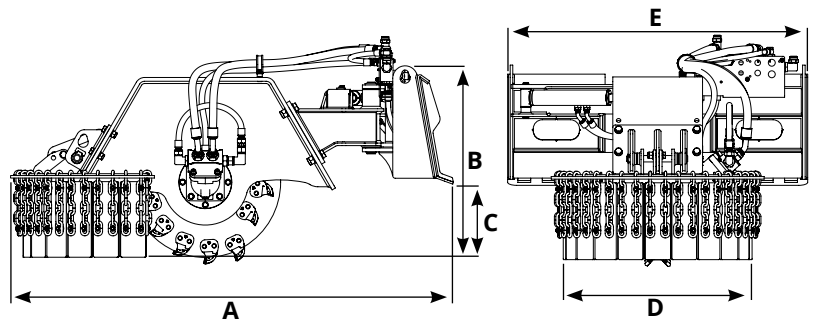
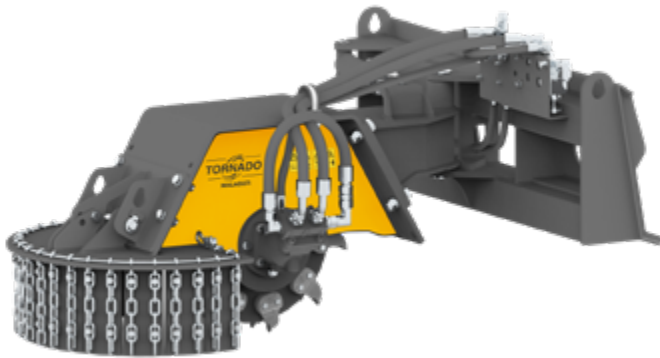

TORNADO	Tornado 350 F	Tornado 350 F	Tornado 450 F	Tornado 450 F	Tornado 450 F	Tornado 600 F	Tornado 600 F	Tornado 600 F	Tornado 600 F PLUS
A (mm)	1366	1366	1529	1529	1529	1734	1734	1734	1734
B (Ømm)	625	625	678	678	678	758	758	758	758
C (mm)	156	156	209	209	209	289	289	289	289
D (mm)	710	710	720	720	720	840	840	840	840
E (mm)	1170	1170	1170	1170	1170	1170	1170	1170	1170
Motor (CC)	12	18	25	28	32	45	50	63	80
Öldurchsatz (L/Min)	16	24	32	36	42	56	64	80	80
Gewicht mit Kupplung (Kg)	310	310	393	393	393	530	530	530	545
Anzahl der Zähne	16	16	20	20	20	28	28	28	28
Druck (BAR)	200-250	200-250	200-250	200-250	200-250	200-250	200-250	200-250	200-250
Max. Gegendruck	15	15	15	15	15	15	15	15	15

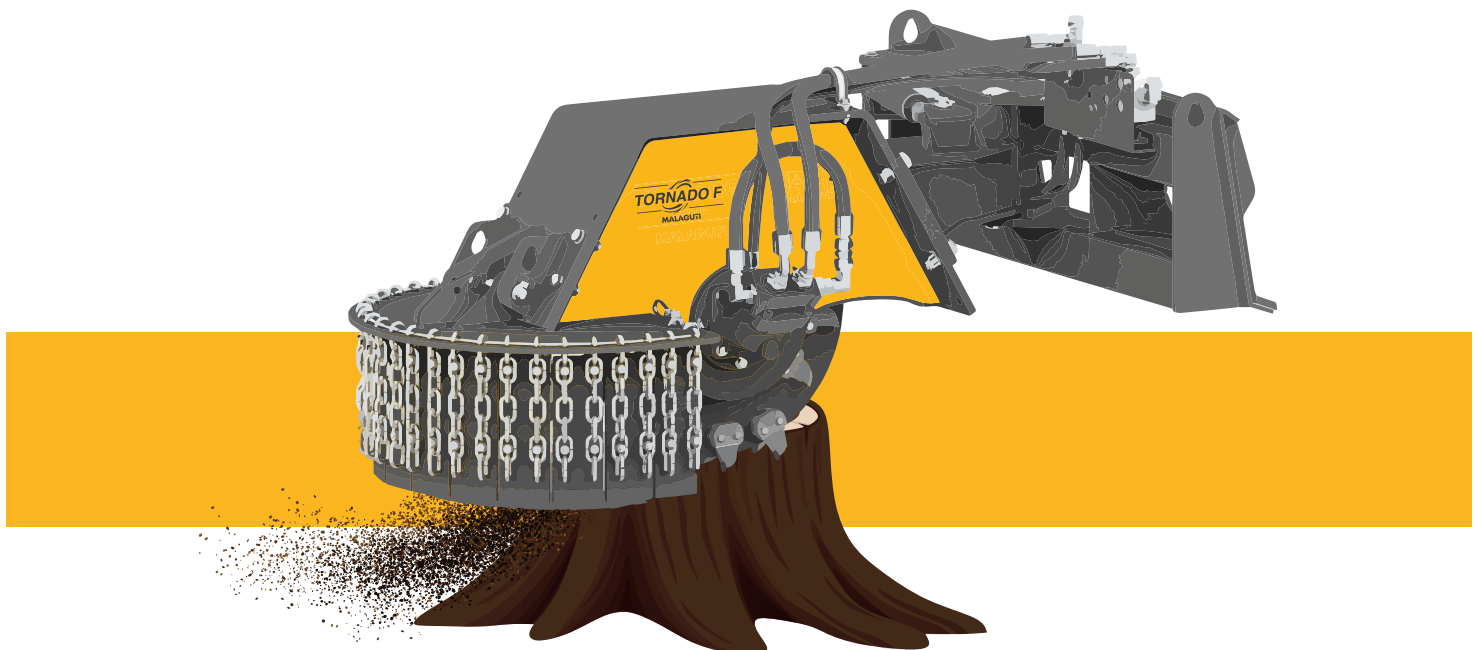



# FRONTANBAU TORNADO

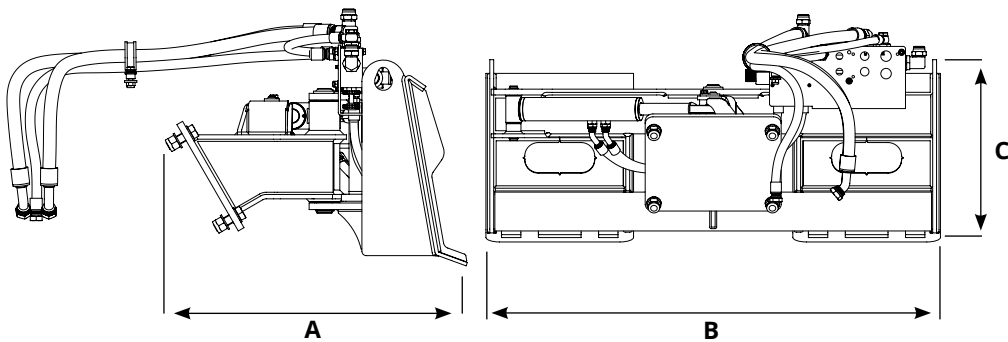
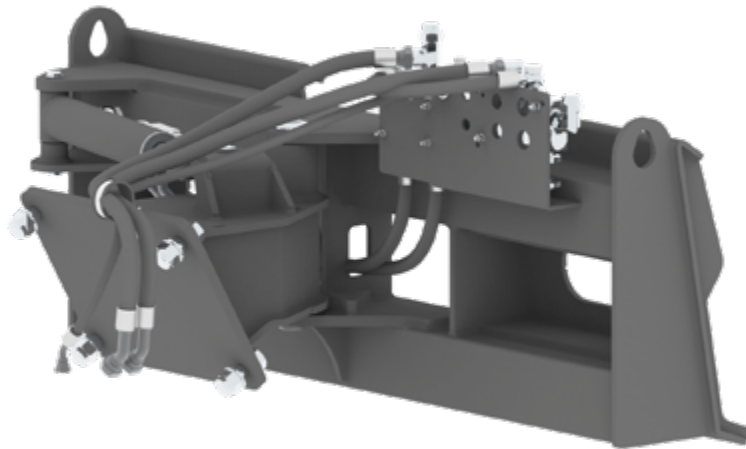

- › Durch den Einsatz des Tornado-Frontanbau ist es möglich, die Wurzelstockfräse auf Arbeitsmaschinen wie Kompaktlader, Mini-Kompaktlader, Mini-Radlader einzusetzen.

Model	A mm	B mm	C mm	Kg.
<b>FRONT-MOUNTED ATTACHMENT TORNADO for 350 / 450 / 600</b>	436	1170	469	170

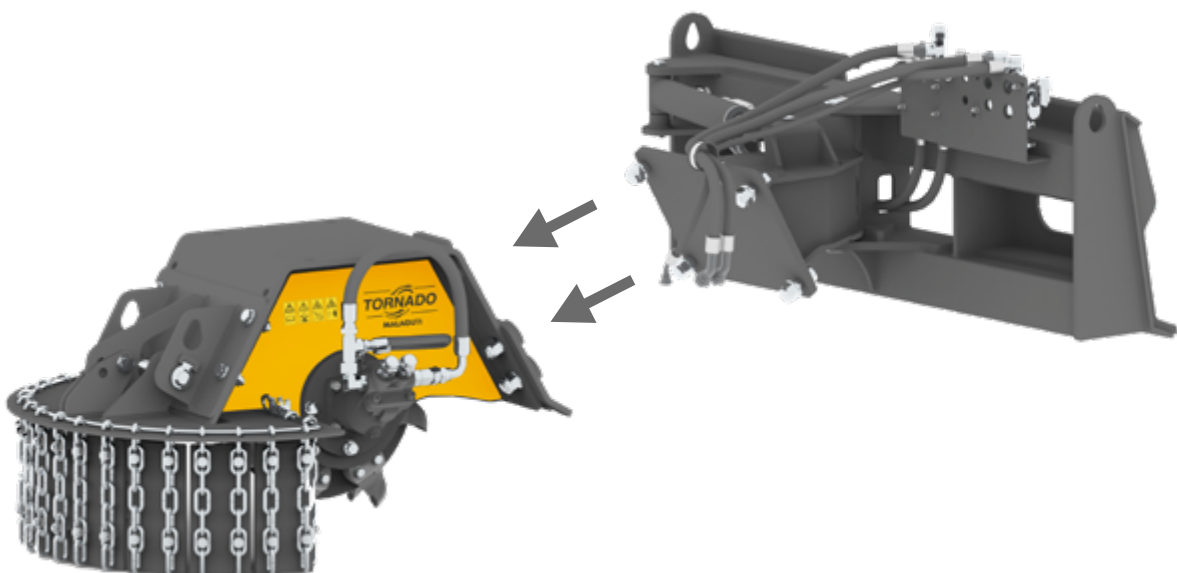

# MALAGUTI

EARTHMOVING EQUIPMENT

 **Officine Malaguti SRL**  
Sant'Agata Bolognese (BO)  
Italy

**Ufficio Commerciale**  
 +39 0547 1932186  
 [commerciale@malagutisrl.com](mailto:commerciale@malagutisrl.com)

 Piazza Plauto, 40  
47027 Sarsina (FC)  
Italy

 [www.malagutisrl.com](http://www.malagutisrl.com)

